

35323(DC180E) Styrofoam Cutter

Operating instruction

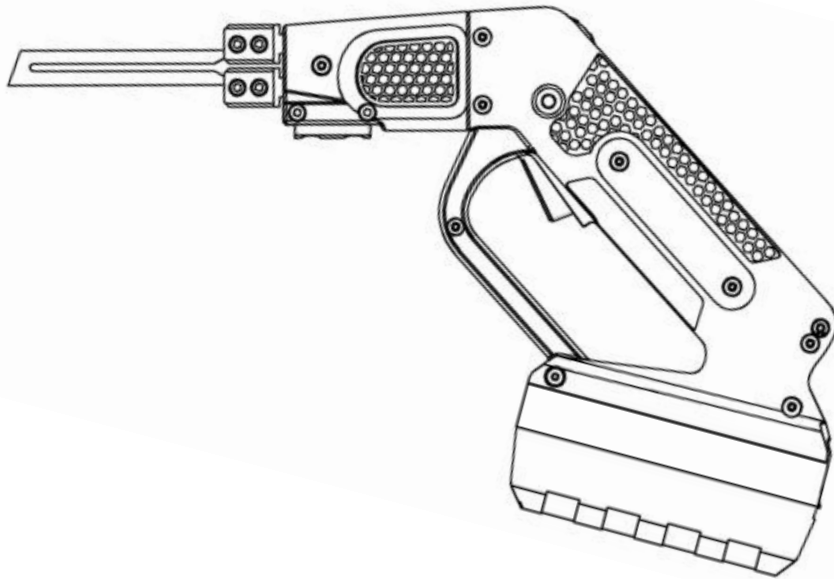

- Please read this instruction carefully before operation
- Take special care on safety prompts in these instructions so as to avoid injury to yourself, other people and objects.
- Please follow the guidelines in these instructions to avoid damage to the tool.

Introduction

The **DC180E** Hot Knife is the first one cordless professional-grade hot cutting tool for foamed plastics. The **DC180E** Hot Knife heats up in seconds and gives the operator temperature control. Never before has working with foamed plastics been this easy, inexpensive and free of mess.

Recommended Use

Expanded Polystyrene (EPS), Extruded Polystyrene (XPS), Polyethylene, Cross-Linked Polyethylene, Polypropylenes, and many other foamed plastics and materials can be easily cut with **DC180E** Hot Knife. Check with the foam manufacturer for safe and proper cutting procedures.

Blade Installation

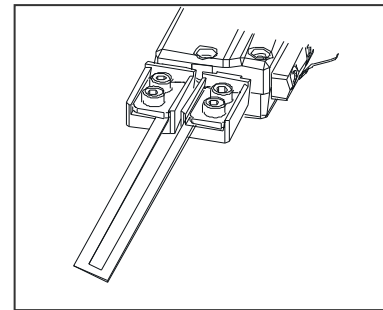

NOTE: Always unpress the trigger of the **DC180E** Hot Knife before installing or removing the blades. Allow sufficient cooling time for blades, blade holders and mounting crews before handling.

Caution 1: The **DC180E** blade have a sharpened razor edge, for the cleanest cut always cut in the direction on the

sharpened edge.

STRAIGHT BLADE:

1. Loosen the screws on the blade holders with the wrench.
2. Slide the blade under the square pressure plates until snug.
3. Securely tighten screws to assure the proper electrical connection. Do not over-tighten.
4. The temperature control knob has 16 click setting that correspond to the graduated ridges on the surface. The smaller the ridge the lower the power setting.

Caution 1: Excessive power output and heat generation may cause the

blade holders to overheat resulting in damage to the unit. Use only the power output for proper cutting. The blade does not need to be red hot to move through foamed plastics.

Operation

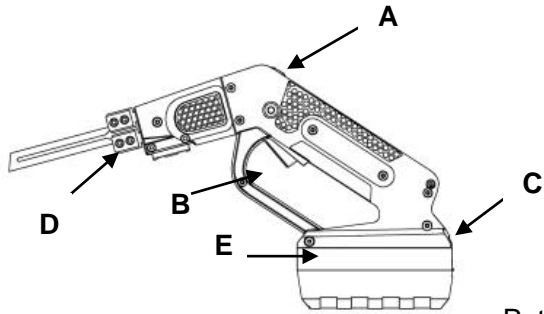

- A) Temperature control knob
- B) Trigger
- C) Battery locking switch
- D) Blade holder
- E) Battery

Put your temperature control knob at midrange setting, place the blade against the edge of the foam and depress trigger. Optimum cutting should be virtually smoke free.

NOTE: For the best results, practice on scrap pieces of foam.

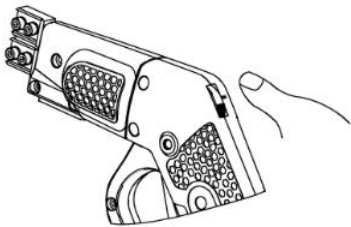

When cutting foam it is best to keep the temperature and speed consistent. If smoke develops during the cut, you are cutting too slow or the blade is too hot which could result in an oversized, uneven cut. This can be remedied by lowering the temperature and intermittently

releasing the trigger during your cut. As the cutting resistance increases, depress the trigger again. The **DC180E** Hot Knife will reach the set temperature within seconds. You can accomplish your cut with minimal smoke using this process. Cutting in this manner will also prolong the life of the knife.

Releasing the trigger approximately one or two inches prior to the completion of the cut will help keep the blade clean and free from buildup.

The selected cutting blade should not be longer than 3/4" past the thickness of your foam board. The foam cools the blade as it cuts. The exposed portion can

overheat and cause your blade to warp.

Guidelines and Caution 3:

1. Always operate the **DC180E** Hot Knife in well ventilated space
2. Never burn off excess residue on the hot knife blade. The blades will overheat, warping the blade and potentially overheating the **DC180E** Hot Knife.
3. Only operate **DC180E** Hot Knife when it is in contact with the insulation board.
4. Keep hot blades away from skin, clothing and other flammable materials.
5. Allow blades to cool before handling. A hot blade may cause injury or burns to exposed surfaces.

Maintenance

Constant use of the **DC180E** Hot Knife may result in polystyrene material build up on blades and the brass holders. This excess polystyrene interferes with the proper electrical and impairs the performance of the blades. **The brass blade holders and blades can be thoroughly cleaned with a wire brush.**

Specification

- **INPUT:** 36 V DC
- **OUTPUT:** 72 Wh
- **Intermittent Operation:** 15s on / 45s off
- **WEIGHT:** 10 Ounces
- **LENGTH:** 260mm
- **TEMPERATURE:** 350 C

Use and handling of the battery tools

- a) Only recharge the battery in charging devices approved by the manufacturer. There is a risk of fire when using a charging device designed for a specific battery type when it is used with other batteries.
- b) In **DC180E** Hot Knife, only use batteries that have been designed for this type of use. Using other battery types may lead to fire and injuries.
- c) When not using the battery, keep it away from paper clips, coins, keys, nails, screws and other small metallic object which may cause the contacts to connect. If the battery contacts short-circuit, it may lead to burns or fire.

d) **Fluid may emerge from the battery if it is used incorrectly.**

Avoid contact with that fluid. In case of accidental contact with the body, rinse the area with water. If the battery fluid comes in contact with the eyes, additionally call for medical help. Emerging battery fluid can lead to burns and irritation of the skin.

- e) Do not open the battery, as this leads to the risk of a short-circuit. Keep the battery away from heat (e.g. permanent sun radiation) and from fire due to risk of explosion.
- f) If the battery is damaged or used in an inappropriate manner, vapors may emerge from it. Get some fresh air and call for medical help in case of complaints. The vapors can lead to irritation of the respiratory tracts.
- g) If the battery is defective, fluid may emerge from it and coat adjacent objects. Check the parts affected, clean them or replace them, if necessary.
- h) Use the battery only with **DC180E**. This is the only way to prevent dangerous overload of the battery.

Quick-replacement of the rechargeable battery

Nominal voltage: 36V

Capacity: Li-ion 2.0Ah (10 cells)

Weight: 610g

Charging device

Input voltage: 100-240V / 50-60 Hz

Out-put voltage: 42V

Out-put current: Max.2.0A

Recharging time: <70 minutes

Weight: 600g

Charging the battery

Note: The battery is partially charged on delivery.

To guarantee full power of the battery, charge it completely in the charger before first use. Pay attention to the charge indicator on the charging device. The Li-ion battery can be recharged at any time without affecting its fatigue life. Interrupting the charging process doesn't damage the battery.

The battery is equipped with temperature monitoring system which only allows for charging between 0°C and 45°C.

Batteries

Li-ion: Do not dispose of batteries in household waste, do not throw them into fire or water. Batteries should be collected and recycled or disposed of in an environment-friendly way. Only valid for EU countries: According to European regulation 91/157/EWG, defective and used up batteries need to be recycled. Batteries that are not functional can be handed over at your store or directly disposed of in an environment-friendly way.

Accessories assembly

Sled:

You can bend flat blade or wire blade with special bending pliers according to your usage, and assembly as below fig.

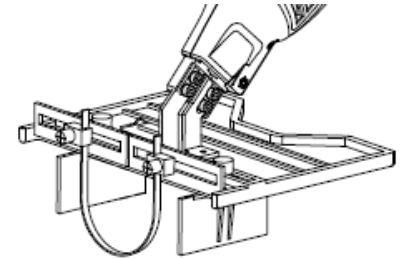

Cutting Guider:

You can make cutting at different angle, assembly as below fig.

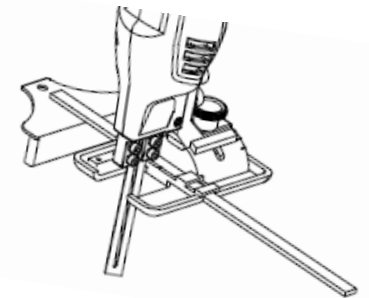

Pipe Groove Adaptor:

You can bend flat blade or wire blade with special bending pliers according to your usage, and assembly as below fig.

